



UD TRUCKS

ALL NEW!

# Quon

Innovation that puts people first.

PRODUCT GUIDE



Going the Extra Mile

ALL NEW!

*Quon*

**BIGGER** PAYLOADS  
**BETTER** FUEL EFFICIENCY  
**BEST** JAPANESE TRUCK

Being the best is a big claim to make. But when you have created a truck like the All New Quon, you know you can back it up. Features that redefine the Japanese truck market and ultimately keep you on the road longer, like bigger payloads, better safety, smarter fuel efficiency and better driver comfort.

**This is why we think this is the best Japanese truck in Australia.**



QUON

UD TRUCKS

QUON

The New Quon features design enhancements in five major areas

# QUON



## SMART DRIVABILITY P10

### Easier to use, smoother to drive

Completely re-designed cabin provides greater driver comfort. ESCOT-VI automated manual transmission is the next evolution in unparalleled operability. Disc brakes, standard on all models, provide a quick and smooth response and excellent braking power. All these innovations contribute to a comfortable environment for drivers.



## SMART FUEL EFFICIENCY AND ENVIRONMENTAL CARE P12

### Cleaner and more powerful

Refinements to the driveline have achieved a high level of fuel efficiency that contributes savings directly to the bottom line. The fuel efficient, powerful, and clean 'GH11 Engine' exceeded heavy-vehicle fuel economy standards during testing in Japan by 5%, while also complying with stringent pPNLT Emissions Standards that exceed Euro 6 emission requirements.



## SMART SAFETY P18

### Safer and more dependable

The New Quon features advanced technologies, such as Traffic Eye Brake System, Lane Departure Warning System and disc brakes.



## SMART PRODUCTIVITY P22

### Better productivity, better efficiency

We've reduced the weight of all models, improving load handling and suspension. As a result of this lower tare weight, carrying capacities have increased across the entire range.



## SMART UPTIME P24

### Longer service intervals for greater peace of mind

The New Quon offers comprehensive after sales services, such as 'UD Genuine Service', 'UD Genuine Parts', 'UD-TRUST: Service agreements', and 'UD Information Service including telematics'. This combination provides an unprecedented level of uptime, as well as the comfort of predictable costs and the peace of mind that your UD is receiving the best parts and service available.

## SPECIFICATION SHEETS P28



# Advanced exterior with a focus on efficiency and function

Our design goal was to develop trucks that drivers are proud to drive. As well as a sophisticated, functional look, the Quon's aerodynamic shape contributes to fuel efficiency. A low cabin design with two-step entry/exit enables easy and safe access. The headlamps use power-saving, long-lasting LED lamps, for bright, clear light that improves night-time visibility for safer driving.



## Superior Aerodynamic Performance

Airflow is directed smoothly from the flat front face to the corners of the truck. The new shape of the wind deflector also improves fuel efficiency.









# Comfortable interior based on design that 'puts people first'

We have re-examined the fundamentals of operability and visibility based on ergonomics. The result is a completely re-designed dashboard area, steering wheel, gear lever, and accelerator pedal. Combined with an instrument panel that provides excellent visibility, these new designs result in a comfortable environment where the driver can concentrate on driving. The black and silver cabin has a modern feel, with careful attention to details that improve the driver's comfort.



# Comfortable and efficient driving performance

ESCOT-VI - the latest evolution in 12-speed automated manual transmission, disc brakes, and an interior designed for driver comfort, provide a sophisticated and comfortable driving experience that reduces driver stress and fatigue.



## Unparalleled operability: ESCOT-VI

ESCOT-VI provides advanced gear change control and suppresses fluctuations in fuel efficiency. Enhancements to hardware and software control achieve fast and accurate gear changes. Quick and smooth gear changes reduce the driver's level of stress and fatigue while contributing to safe driving. Performance is also improved on uneven surfaces and muddy roads.

## Simple and easy-to-use gear lever

The ESCOT-VI gear lever uses a straight shifting pattern, an evolution in simple and easy-to-use design.

- R: Reverse** For smooth driving in the reverse direction at slow speed.
- N: Neutral** Gear lever position for when the truck is parked.
- D: Drive** Programmed for the quick gear changes and fuel efficient driving of a professional driver. You can also use the convenient +/- button on the right side of the gear lever to change up and down.
- M: Manual** Manual mode.



The system provides a full set of switches to set, change, and cancel vehicle speed. There's also an ECO OFF switch to change between ECO mode and ECO OFF mode.

## Traffic Eye Cruise Control

This system uses millimetre-wave radar to detect the vehicle in front and maintain a fixed distance from it. If the vehicle in front accelerates, the Quon will accelerate within the range of speed and distance the driver has set using the switches on the control panel. You can set a speed of 30 km/h or higher, and if the Quon's speed falls below 15 km/h Cruise Control function self-cancels.

## 4-Spoke Steering Wheel

Using ergonomic research, we re-designed the shape of the steering wheel to give a more comfortable grip that reduces driver fatigue. We've placed the most important switches conveniently for easy access to functions and information. This ensures that the driver's line of sight and operation are along the same axis, for efficient, safe, and reliable operability.

## Instrument panel with excellent visibility

We've arranged the driving information and LED indicators on the instrument panel in an easy-to-understand layout that provides excellent visibility. Information is displayed in zones arranged according to warning priority, with the most important information at the top. A large 5-inch color LCD multi-display is mounted in the centre of the instrument panel.



## Dashboard designed for driver comfort

We've designed a functional black-and-silver dashboard that skilfully combines straight lines and curves. This design enhances driver operability and visibility and provides the optimal arrangement of multi-display monitor, switches, equipment, and instruments. Switches are set to light up when in use and at night, so the state of any switch can be easily understood with a quick glance.

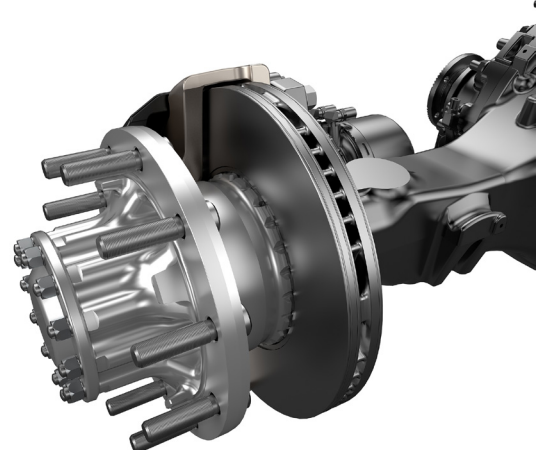

## Disc brakes for reliable and powerful braking

Disc brakes give a quick and smooth brake pedal response and reliable braking, even on long descents when hauling a full load. By combining a variety of advanced brake systems, such as brake blending and the Traffic Eye System, we have achieved comfortable braking that is easy on cargo, while also reducing driver fatigue.



# Driveline with Advanced Fuel Efficiency

The New Quon driveline features the clean 'GH11 Engine' with improved horsepower and torque, and the ESCOT-VI automated manual transmission with enhancements to fuel efficiency. The driveline uses advanced technology to achieve high fuel efficiency and smooth, comfortable driving with little fatigue.

## Fuel efficient, powerful, clean 'GH11 Engine'

The 'GH11 Engine' uses the unique properties of both a unit injector and a common rail system. The GH11 generates torque in a wide revolution range, starting from low revolutions, and features a new fuel injection system and changes to the shape of the combustion chamber. These advances enabled the GH11 to exceed Japanese heavy vehicle fuel economy standards by 5%, and to comply with the stringent pPNLT Emissions Standards, which exceed Euro 6 emission requirements.

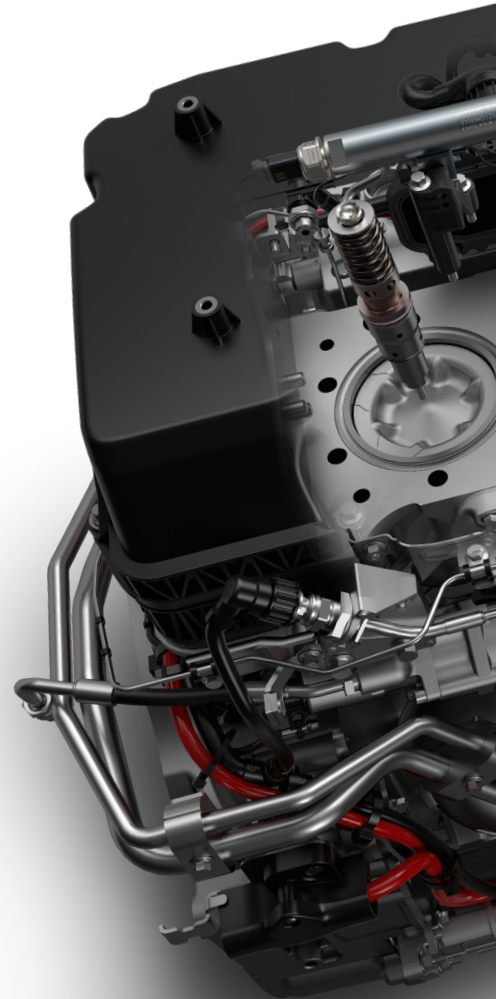

### GH11TB390PS

287KW(390PS) / 1,600rpm  
1,750Nm(178.5kg•m) / 900-1,500rpm

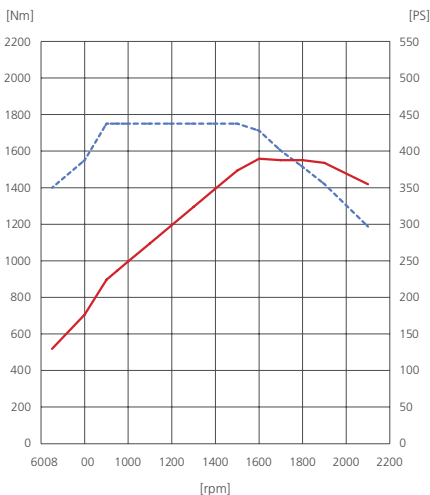

### GH11TC420PS

309KW(420PS) / 1,600rpm  
1,900Nm(193.kg•m) / 900-1,500rpm

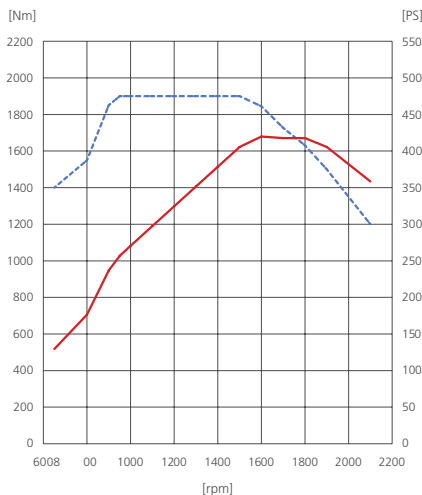

### GH11TD460PS

338KW(460PS) / 1,800rpm  
2,200Nm(224.3kg•m) / 1,200-1,400rpm

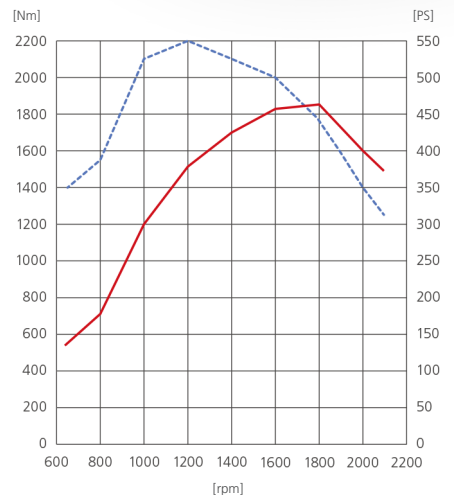

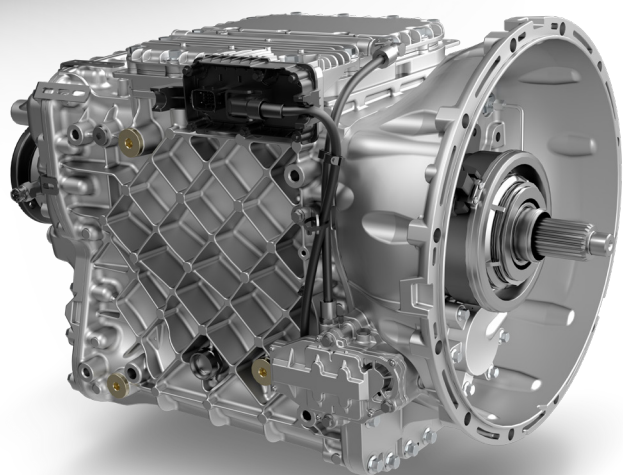
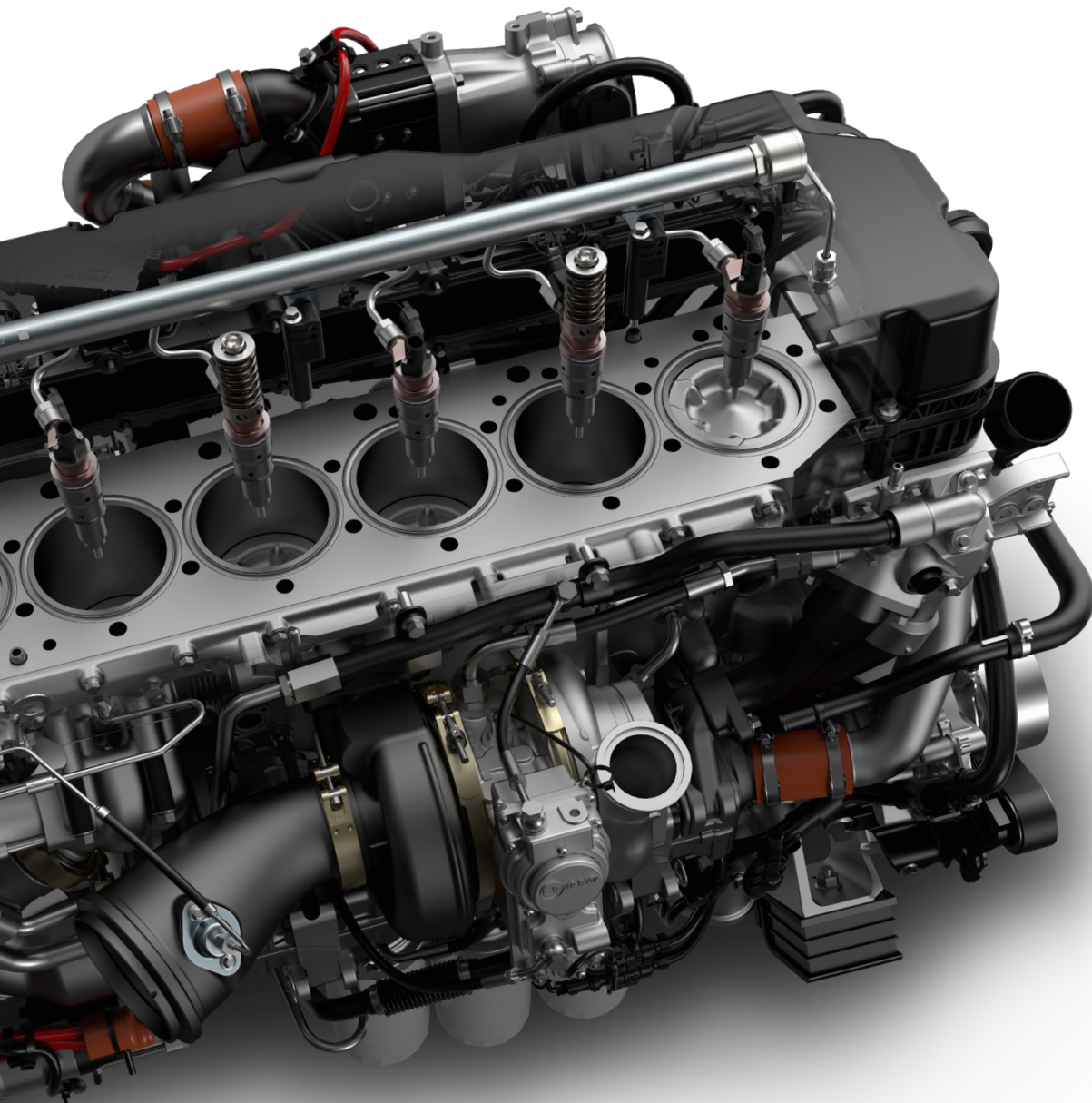

### ESCOT-VI for enhanced fuel efficiency

Evolutions in the hardware and software controls of the ESCOT-VI 12-speed automated manual transmission provide improved gear shifting leading to increased fuel efficiency.



Smart Fuel Efficiency and Environmental Care

# Advanced Functions for Enhanced Fuel Efficiency

When the driver starts the Quon, ECO mode, ESCOT Roll, Acceleration Limiter, Soft Cruise Control, and other features automatically turn on. Fuel efficient driving begins as soon as the engine is running.



Quon

UD TRUCKS

Quon



## Smart Fuel Efficiency and Environmental Care







## Fuel efficient Driving in ECO Mode

ESCOT Roll and other functions that enhance fuel efficiency are engaged as soon as the engine is turned on.

### ESCOT Roll

This function enhances fuel efficiency while coasting, by reducing fuel consumption due to re-acceleration. It comes on automatically if certain conditions\* are satisfied while in ECO mode. If the truck goes too fast while Traffic Eye Cruise Control is ON, ESCOT Roll cancels automatically.

\*When the gear lever is in the D range, the exhaust brake switch is OFF, and coasting in 7th gear or higher on a flat road.

### Acceleration Limiter

The acceleration limiter is programmed to limit sudden acceleration above a certain level - even when flooring the accelerator pedal - to enhance fuel efficiency and maintain stable driving. If acceleration is required, the driver can hit the ECO OFF switch on the steering wheel to remove the limitation on strong acceleration.

### Soft Cruise Control

Cruise Control suppresses sudden acceleration, controls engine speed, and returns the truck to the set vehicle speed, to provide excellent fuel efficiency.

### 'Nenpi Coach' for fuel efficiency advice

The 'Nenpi Coach' system analyses driving patterns for a specified time period, then displays optimal fuel efficiency advice on the multi-display monitor in an easy-to-read format. The driver can also check other detailed information and optimal driving techniques to improve fuel economy.

### UD Telematics

Part of the UD Information Service, the UD Telematics system is an asset that every operator should rely on to provide valuable vehicle operational data and location information, including fuel efficiency reporting.

### Driver Development

UD Trucks have a dedicated driver development team who deliver driver development tools to dealers, fleets and private customers. These lessons are designed to help drivers fine tune their driving style so as to ensure both safer and more economical progress on the road. Vehicles can be driven in a more fuel efficient manner, creating significant savings for the company as well as the environment.

# Safer and more dependable

Safe driving is easier if the truck can predict potential dangers and warn the driver. To do this, the Quon features advanced safety systems such as the Traffic Eye Brake System (standard) and the Driver Alert System (optional).

The goal is to achieve 'safety that puts people first' by providing safe driving conditions for drivers, while maintaining safety in the surrounding environment.

Disc brakes with high heat dissipation and superior fade resistance improve safe driving.

## Active safety: Improved driver safety

### Traffic Eye Brake System

This system uses millimetre-wave radar and a camera to monitor the area in front of the truck. If it detects a potential collision it sounds an alarm, displays a warning lamp and a warning message. If the truck continues to close on the vehicle ahead, the system applies the brakes automatically to slow the truck and prevent the collision.

### Traffic Eye Brake System Operation Figure



1. Uses both millimetre-wave radar and camera to monitor conditions in front of the truck.

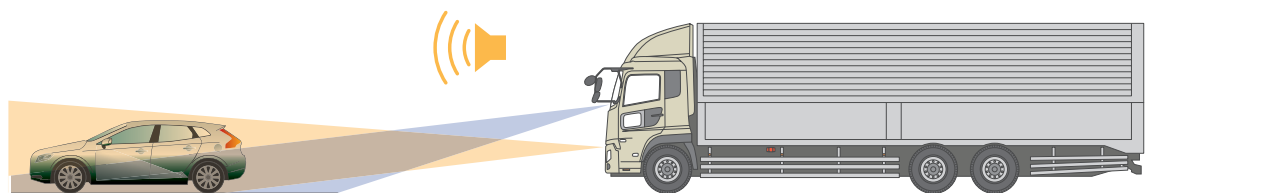

2. While driving, if the system detects a chance of collision with the vehicle ahead, it sounds an alarm and displays a warning indicator to alert the driver.

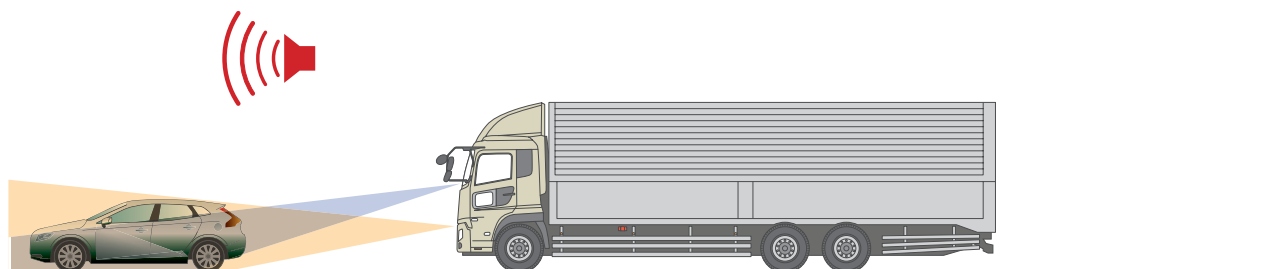

3. If the vehicle gets close enough for a collision to be possible, the system quickly applies the brakes to reduce the potential damage from a collision.

NOTE: The Traffic Eye Brake System provides assistance for safe driving, but does not guarantee that all collisions will be avoided. It might not be possible to use this system on some roads and in some weather conditions. Please take care to drive safely without total reliance on this system.

### Passive safety: Suppressing damage to a minimum

- Highly rigid cabin
- Side door beams
- FUPS\*
- SRS airbags
- Seat belts with pre-tensioners
- Steering wheel & column with impact absorption function
- ECE-R29 cab strength compliant

\*Front Underrun Protection System

### Active safety: Predicting risk for driver safety

- Traffic Eye Brake System
- Traffic Eye Cruise Control
- LDWS (Lane Departure Warning System)
- UDSC (UD Stability Control)
- Driver Alert System (optional)

### Basic safety: Contributing to reducing fatigue while driving, supporting safe driving

- LED Headlamps
- Disc brakes
- Emergency Braking System
- UD Extra Engine Braking (UD EEB)
- UDSC (UD Stability Control)
- Safe Brake Blending
- Immobiliser
- Easy two-step entry/exit & long grip (driver's side)

### Traffic Eye Brake System Components

The Traffic Eye camera functions as a sub-sensor when detecting stopped vehicles.



The Millimetre-wave radar functions as the main sensor when detecting the vehicle ahead.

Highly rigid cabin

Traffic Eye Brake System

UDSC

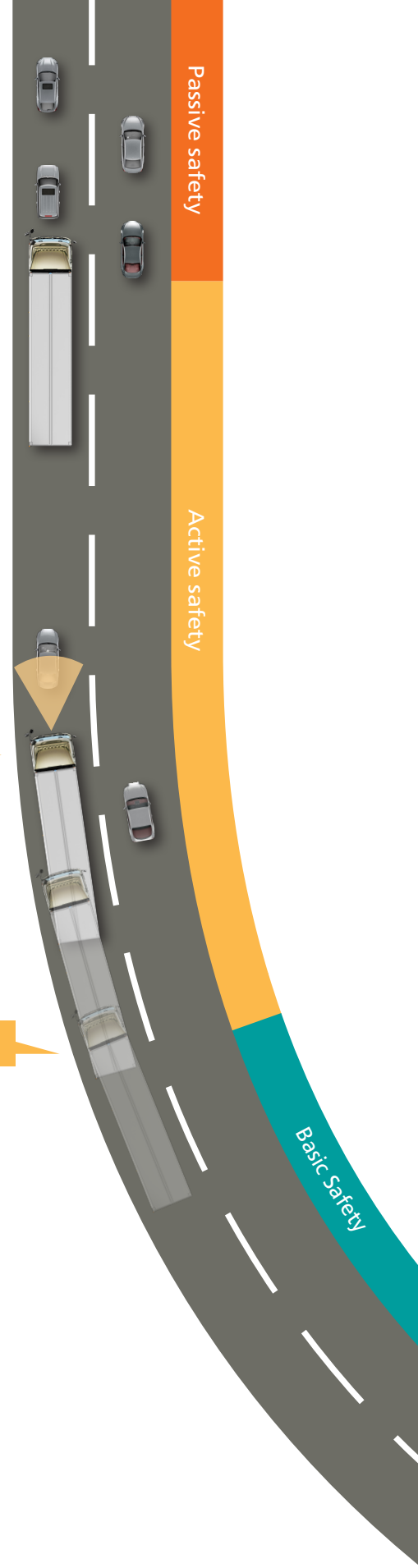

## Active safety: Predicting risk for driver safety



### Lane departure warning system

The in-cab camera detects the traffic lanes to the left and right. If the driver unintentionally leaves the lane while driving at 60km/h or faster, the system sounds an alarm and flashes an indicator.

This function is not triggered if the brakes and turn indicators are used.



### Driver Alert System (optional)

The in-cab camera analyses the positional relationship between traffic lanes and vehicles, and estimates the driver's level of concentration based on irregular or shaky steering. If the system determines that the driver's level of concentration has dropped, it activates a two-step alarm and displays a warning message on the multi-display to alert the driver and suggest a break.

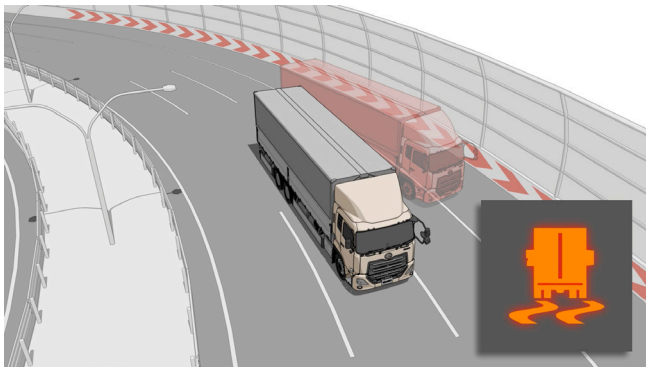

Drifting (snowy and muddy roads, etc.)

### UD Stability Control (UDSC)

If the UDSC sensor detects conditions in which the truck could become unstable, such as curves or slippery road surfaces, the system applies suitable control to engine output, brakes, and braking power to each tyre to keep the truck stable. UDSC is standard on all models.

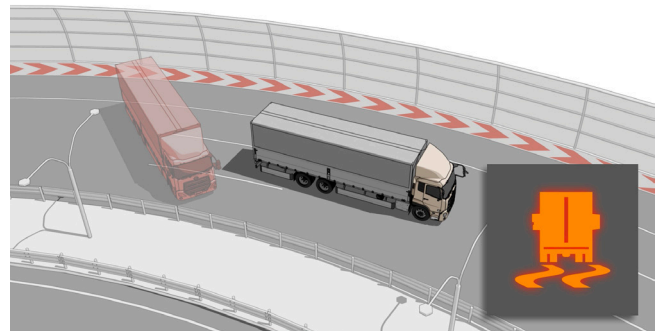

Sliding/Spinning

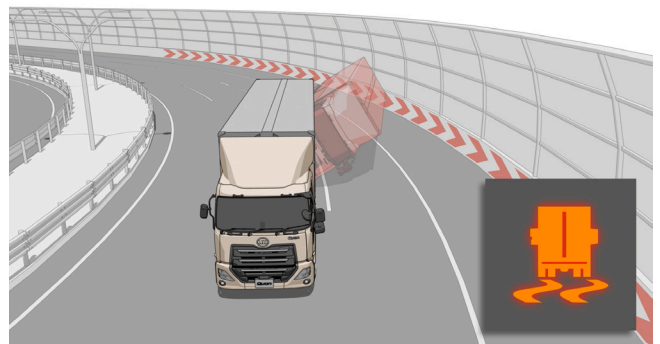

Rollover

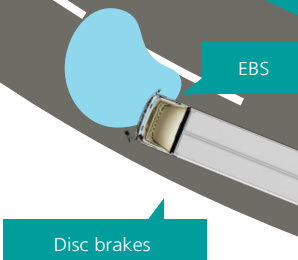

## Basic safety: Reducing fatigue while driving

### LED headlamps

The long-lasting LED lamps used for low beam provide a bright and clear light to improve night-time visibility for safe driving.



### Disc brakes

Disc brakes with high heat dissipation and superior fade resistance provide reliable braking performance even on long descents. As they are less susceptible to water penetration, they also provide stable braking performance even in adverse conditions. They respond quickly and smoothly to the brake pedal and reduce the impact of braking, to prevent damage to your valuable cargo.

### Emergency Braking System

This system uses dual monitoring with a millimetre-wave radar and camera to warn the driver of a potential collision with the vehicle in front. If the chance of a collision increases, it applies the brakes automatically to reduce damage.

### UD EEB (UD Extra Engine Braking)

The UD EEB function on the GH11 engine maintains a high engine rpm to ensure maximum auxiliary braking performance.

### Safe Brake Blending

Brake blending provides superior braking efficiency and optimal balance between the main brakes and auxiliary brakes, simply by pressing the brake pedal.

### Immobiliser

You can only start the engine with the dedicated key, helping to reduce the risk of vehicle theft. The immobiliser is equipped as standard on all models.



### Long grip on driver's side and two-step floor height

Long grip and two-step entry/exit make it easier to get in and out, while the floor height has been lowered to improve direct visibility.

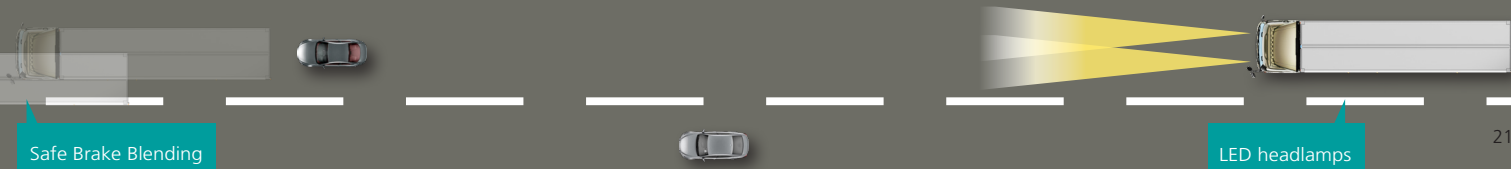

# Better productivity, better efficiency

The key to efficient transport is increased payload. Quon uses disc brakes and high tensile steel rails for the main frame to reduce the vehicle's weight.

Our chassis designs allow for simpler body mounting providing a greater range of options.

## Reduced vehicle weight

Disc brakes and high-tensile steel rails for the main frame reduce weight to improve overall productivity.

## Light and strong frame

High-tensile steel rails and reduced height of the frame cross-section maintain strength, while reducing weight, to achieve further improvements in loading performance.





### Improved load handling, uneven load adjustment function

The uneven load adjustment function automatically adjusts any lateral differences in height on trucks with new air suspension. This improves handling when loading from the side of the truck.

### A new air suspension with increased height adjustment range

The new air suspension features increased adjustment range. This enables optimal height adjustment for loading docks and connecting trailers, with an adjustment width of +140mm upward from the neutral position.



# Reliability and durability you can count on

Highly reliable and durable trucks are essential for maintaining a high level of uptime and providing a distribution business that shippers can trust.

By achieving a high level of quality across the entire truck, quality that has passed tests in strict environments, Quon gives your business the reliability and durability you can count on.



## Rigorous testing

A variety of tests, that simulate the harshest conditions have been conducted in the New Quon. We can confirm that the engine will start, even in the harshest conditions. We used this process to test disc brakes and UDSC (UD Stability Control) to verify driving stability on uneven roads. These functions also improve performance in muddy areas. Such rigorous tests improve the reliability and durability of the New Quon.

Starting assistance function for snowy roads and muddy areas is standard for the ESCOT-VI automated manual transmission.



# Advanced maintenance for a high level of uptime

Uptime is critical for the distribution business, and the key to uptime is ensuring the required maintenance is done at the optimum intervals.

An excellent level of maintenance for your Quon and the long intervals between the replacements of genuine parts greatly contribute to reducing the life cycle cost.

## Hub bearing unit for improved maintenance

Sealed type hub bearing unit, for improved maintenance during inspections.

## Cab for easy daily maintenance

All of the equipment that is required when performing daily inspections is easily accessible without tilting the cab. The cab tilts to 65 degrees for a large work space.

The grille should be opened before tilting the cab.

## Periodic replacement parts and long replacement intervals

We use disc brakes that do not require expanders, and have reduced the number of parts that need to be replaced regularly. The differential gear oil that we use is a high-quality synthetic oil that is highly heat-resistant and does not degrade easily, enabling longer replacement intervals.

## Long-lasting LED headlamps

We use long-lasting and power-saving LED lamps. There is little degradation from turning the lamps on and off, and they provide clear and bright light for a long time, contributing to a low running cost.

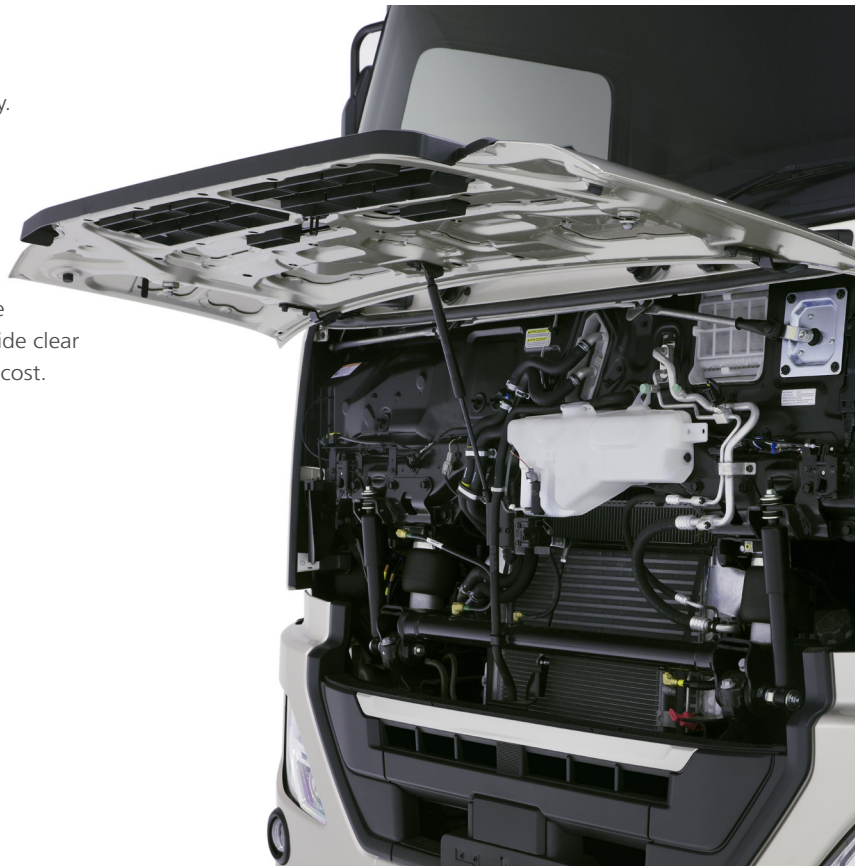

# Maximising uptime is the decisive factor in business: 'UD Extra Mile Support'

After delivery, maintenance using the latest technology and genuine parts is important for maximising uptime, driving performance, fuel efficiency, and safety.

With 'UD Genuine Service', our knowledgeable and experienced mechanics perform the optimal maintenance with UD Trucks' specialised tools.

Genuine parts provide peace of mind. Our high-quality 'UD Genuine Parts' have passed strict tests and contribute to maintaining quality for a long period and maximising uptime.

If you do experience an unplanned stop, our nationwide service network provides prompt support to keep downtime to a minimum.



## 'UD Extra Mile Support' Solutions

Fuel Efficiency, Improved Uptime, and Full Support from the largest dealer network in Australia and New Zealand.





## UD Genuine Service

With the UD Trucks service network, our professional service staff uses UD Trucks' specialised tools, computerised vehicle diagnostic equipment, and high-quality genuine parts to support our customers.

- Customised UD service planning based on the conditions of customers' trucks, for peace of mind from the time they are delivered



## Service Agreements 'UD-Trust Service Agreements'

UD Trucks provides high-quality UD genuine service based on a maintenance plan created according to your vehicle usage.

Details required for truck maintenance are packaged in a Service Agreement that maximises uptime, including:

- Vehicle inspections, regular inspections, and preventive maintenance performed by professionals using reliable technology, for daily peace of mind.
- UD genuine service using UD genuine parts.
- Optimal preventive maintenance with a nationwide service network.
- Improvements in uptime and fuel efficiency to reduce total costs.
- Flat-rate cash flow management plan for the effective use of funds.

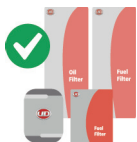

## UD Genuine Parts

Genuine parts that are designed and developed for UD must pass strict tests to ensure that they provide a stable level of quality and a high level of durability. We also provide prompt support with a full inventory of parts and a system for their speedy delivery.

- Maintain truck performance and quality.
- Reduce occurrence of unexpected faults, and maintain a high level of uptime.
- UD Trucks 24 months parts warranty when the part is fitted in an authorised service centre.
- High-quality exchange parts.



## UD Warranty

Our manufacturer's warranty provides support for safe driving.

For more information about the details of the warranty, please refer to the Warranty Sheet.



## UD Roadside Assistance

Coordinators with specialised knowledge are assigned to each of our call centres. They work closely with our nationwide service personnel who have received specialised training, to provide prompt and efficient customer support.

- Step-by-step customer support 24/365, with a single phone call.
- Truck condition and location information you provide is shared with service personnel, for efficient resolution of issues and reduced downtime.
- If on-site assistance is required, we dispatch personnel promptly from the location nearest to you.



## UD Information Service

The UD Information Service system is an asset that every operator should rely on to provide valuable vehicle operational data and location information. Fuel efficiency reporting is just only one of the many reports available.

### "NENPI COACH" FOR FUEL-EFFICIENCY ADVICE

The "Nenpi Coach" system analyses driving patterns for a specified time period, then displays optimal fuel-efficiency advice on the multi-display monitor in an easy-to-read format.

### UD TELEMATICS

Part of the UD Information Service, UD Telematics monitors driver and truck performance, with real-time analysis and top-line reporting.

### MULTIMEDIA AUDIO

The state of the art multimedia audio system includes a full touch screen display, digital radio, media player and includes commercial vehicle specific navigation.



## UD Financial Services

UD Trucks provides integrated financial services. UD Financial Services understand our customers' businesses, and provide detailed solutions based on their requirements. Services such as leases, hire purchase, and maintenance services, all provided within a collective agreement.

## Specifications

# CD 25 390

6x2 Rigid



## SPECIFICATIONS

<b>Power:</b>	287 kW (390 PS) @ 1600 rpm
<b>Torque:</b>	1750 Nm (1290 lb.ft) @ 900 rpm
<b>Transmission:</b>	ESCOT-VI automated manual transmission (AMT)
<b>Suspension:</b>	Air bag suspension
<b>Overall length:</b>	11467 mm
<b>Overall width:</b>	2490 mm
<b>Wheelbase:</b>	5800 mm* (V-wheelbase)
<b>GVM:</b>	25000 kg
<b>GCM:</b>	45000 kg

Note: CD 25 390 shown may not be representative of actual vehicle.  
\*Wheelbase measurements are from steer axle to first drive axle.

## NEW QUON UNIQUE FEATURES



### SMART FUEL EFFICIENCY AND RESPECT FOR THE ENVIRONMENT

GH11 engine: even more fuel efficient, powerful and clean.



### SMART UPTIME

New Quon has been designed to further optimise uptime, with superior reliability and increased maintenance intervals.



### SMART SAFETY

Active safety has been improved with mechanical and electronic upgrades throughout.



### SMART PRODUCTIVITY

Increased payload, reduced vehicle weight.



### SMART DRIVABILITY

The cabin has been completely redesigned with the user's comfort in mind, with improved ergonomics and visibility allowing the driver to concentrate on driving.

## MECHANICAL SPECIFICATION

### ENGINE MODEL

<b>Model:</b>	GH11TB
<b>Layout:</b>	6 in-line
<b>Maximum power (rpm):</b>	287 kW (390 PS) @1600 rpm
<b>Maximum torque (rpm):</b>	1750 Nm (1290 lb.ft) @ 900 rpm
<b>Bore X stroke:</b>	123 mm x 152 mm
<b>Displacement:</b>	10837 cc (11 litres)
<b>Emission standard:</b>	pPNLT (Exceeds Euro 6 emission requirements)

### TRANSMISSION

<b>Make:</b>	UD Trucks
<b>Model:</b>	ESCOT-VI
<b>Description:</b>	Automated manual transmission (AMT) 12 forward & 2 reverse gears
<b>Shift type:</b>	Electronic shifter with fully automatic or manual control

### Gear Ratios:

<b>1<sup>st</sup></b>	14.94	<b>7<sup>th</sup></b>	3.44
<b>2<sup>nd</sup></b>	11.73	<b>8<sup>th</sup></b>	2.70
<b>3<sup>rd</sup></b>	9.04	<b>9<sup>th</sup></b>	2.08
<b>4<sup>th</sup></b>	7.09	<b>10<sup>th</sup></b>	1.63
<b>5<sup>th</sup></b>	5.54	<b>11<sup>th</sup></b>	1.27
<b>6<sup>th</sup></b>	4.35	<b>12<sup>th</sup></b>	1.00
<b>Rev 1</b>	17.48	<b>Rev 2</b>	13.73

**PTO capacity:** 500 nm @ 103% or 81%

### BRAKES

<b>System type:</b>	Electronic Braking System (EBS) with disc brakes
<b>Front/Rear:</b>	430 mm rotors / 430 mm rotors
<b>Parking/Emergency Brake:</b>	Spring park brake
<b>Auxiliary Brake:</b>	Exhaust plus engine compression type (EEB)

### CLUTCH

<b>Type:</b>	Single plate
<b>Disc diameter:</b>	430 mm (17")

### STEERING

<b>Type:</b>	Hydraulic assist
<b>Min.turning:</b>	9900 mm

### AXLE AND LOAD

<b>Model (rear):</b>	RSS1344C
<b>Front axle load limit:</b>	8200 kg
<b>Rear axle load limit:</b>	20000 kg
<b>Final gear ratio:</b>	3.08 or 3.36

Reduction type: Single reduction

### SUSPENSIONS

<b>Front:</b>	Front parabolic leaf spring suspension
<b>Rear:</b>	8 air bags electronically controlled

### TYRE:

<b>Tyre size front:</b>	295/80 R22.5
<b>Tyre size rear:</b>	11 R22.5
<b>Tyre brand:</b>	Bridgestone

### FUEL TANK

<b>Capacity:</b>	400 litre aluminium tank with lockable cap on LHS
<b>Optional:</b>	400 litres auxiliary on RHS

## MAJOR DIMENSIONS

Variant	Mass (kg)				Vehicle Dimensions (mm)														UD order code
	Wheelbase code	GVM*	GCM	Total Tare <sup>1</sup>	WB	TWB	OL	OW	OH	FT	RT	AS	ROH	CA	GC <sup>2</sup>	FHF <sup>2</sup>	FHR <sup>2</sup>	Turning radius (kerb to kerb)	
UD - Air	V	25000	45000	7409	5800	6485	11467	2490	2970	2062	1851	1370	4145	5085	249	1010	1012	9900	CD25390VAA

\* Rated GVM and axle capacities are subject to Federal, State and Territory legal requirements.

1. Mass is an estimation based only on standard model, includes fluids (no diesel fuel or Adblue®). Excludes spare tyre carrier, spare wheel, driver & tools.

2. Based on vehicle with standard wheels and tyres

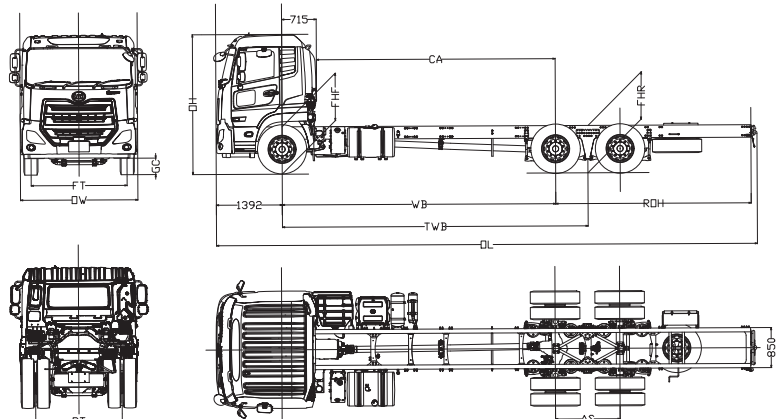

## Specifications

# CW 26 390

6x4 Rigid



## SPECIFICATIONS

<b>Power:</b>	287 kW (390 PS) @ 1600 rpm
<b>Torque:</b>	1750 Nm (1290 lb.ft) @ 900 rpm
<b>Transmission:</b>	ESCOT-VI automated manual transmission (AMT)
<b>Suspension:</b>	Air bag or leaf suspension
<b>Overall length:</b>	7867 mm (L-wheelbase) 11167 mm (T-wheelbase) 11467 mm (V-wheelbase)
<b>Overall width:</b>	2490 mm
<b>Wheelbase:</b>	3700 mm* (L-wheelbase) 5350 mm* (T-wheelbase) 5800 mm* (V-wheelbase)
<b>GVM:</b>	26000 kg
<b>GCM:</b>	50000 kg

Note: CW 26 390 shown may not be representative of actual vehicle.  
\*Wheelbase measurements are from steer axle to first drive axle.

## NEW QUON UNIQUE FEATURES



### SMART FUEL EFFICIENCY AND RESPECT FOR THE ENVIRONMENT

GH11 engine: even more fuel efficient, powerful and clean.



### SMART UPTIME

New Quon has been designed to further optimise uptime with superior reliability and increased maintenance intervals.



### SMART SAFETY

Active safety has been improved with mechanical and electronic upgrades throughout.



### SMART PRODUCTIVITY

Increased payload, reduced vehicle weight.



### SMART DRIVABILITY

The cabin has been completely redesigned with the user's comfort in mind, with improved ergonomics and visibility allowing the driver to concentrate on driving.

## MECHANICAL SPECIFICATION

### ENGINE MODEL

<b>Model:</b>	GH11TB
<b>Layout:</b>	6 in-line
<b>Maximum power (rpm):</b>	287 kW (390 PS) @ 1600 rpm
<b>Maximum torque (rpm):</b>	1750 Nm (1290 lb.ft) @ 900 rpm
<b>Bore X stroke:</b>	123 mm x 152 mm
<b>Displacement:</b>	10837 cc (11 litres)
<b>Emission standard:</b>	pPNLT (Exceeds Euro 6 emission requirements)

### TRANSMISSION

<b>Make:</b>	UD Trucks		
<b>Model:</b>	ESCOT-VI		
<b>Description:</b>	Automated manual transmission (AMT) 12 forward & 2 reverse gears		
<b>Shift type:</b>	Electronic shifter with fully automatic or manual control		
<b>Gear Ratios:</b>			
<b>1<sup>st</sup></b>	11.73	<b>7<sup>th</sup></b>	2.70
<b>2<sup>nd</sup></b>	9.21	<b>8<sup>th</sup></b>	2.12
<b>3<sup>rd</sup></b>	7.09	<b>9<sup>th</sup></b>	1.63
<b>4<sup>th</sup></b>	5.57	<b>10<sup>th</sup></b>	1.28
<b>5<sup>th</sup></b>	4.35	<b>11<sup>th</sup></b>	1.00
<b>6<sup>th</sup></b>	3.41	<b>12<sup>th</sup></b>	0.78
<b>Rev 1</b>	13.73	<b>Rev 2</b>	10.78
<b>PTO capacity:</b>	500 nm @ 103% or 81%		

### BRAKES

<b>System type:</b>	Electronic Braking System (EBS) with disc brakes
<b>Front/Rear:</b>	430 mm rotors / 430 mm rotors
<b>Parking/Emergency Brake:</b>	Spring park brake
<b>Auxiliary Brake:</b>	Exhaust plus engine compression type (EEB)

### CLUTCH

<b>Type:</b>	Single plate
<b>Disc diameter:</b>	430 mm (17")

### STEERING

<b>Type:</b>	Hydraulic assist
<b>Min.turning:</b>	6900 mm (L-wheelbase) 9300 mm (T-wheelbase) 9900 mm (V-wheelbase)

### AXLE AND LOAD

<b>Model (rear):</b>	RTS2370A
<b>Front axle load limit:</b>	8200 kg
<b>Rear axle load limit:</b>	21000 kg
<b>Final gear ratio:</b>	4.13 or 4.50

<b>Reduction type:</b>	Single reduction
------------------------	------------------

### SUSPENSIONS

<b>Front:</b>	Parabolic leaf spring suspension
<b>Rear:</b>	8 air bag electronically controlled or Parabolic leaf spring suspension with rubber cushion

### TYRE:

<b>Tyre size front:</b>	295/80 R22.5
<b>Tyre size rear:</b>	11 R22.5
<b>Tyre brand:</b>	Bridgestone

### FUEL TANK

<b>Capacity:</b>	400 litre aluminium tank with lockable cap on LHS
<b>Optional:</b>	400 litres auxiliary on RHS (Not available on L-wheelbase)

## MAJOR DIMENSIONS

Variant	Mass (kg)					Vehicle Dimensions (mm)															UD order code
	Wheelbase code	GVM*	GCM	Total Tare <sup>1</sup>	WB	TWB	OL	OW	OH	FT	RT	AS	ROH	CA	GC <sup>2</sup>	FHF <sup>2</sup>	FHR <sup>2</sup>	Turning radius (kerb to kerb)			
UD - Leaf	L	26000	50000	7830	3700	4385	7867	2490	2970	2062	1851	1370	2645	2985	249	1022	1091	6900	CW26390LAL		
	T	26000	50000	8063	5350	6035	11167	2490	2970	2062	1851	1370	4295	4635	249	1026	1089	9300	CW26390TAL		
UD - Air	V	26000	50000	7956	5800	6485	11467	2490	2970	2062	1851	1370	4145	5085	249	1027	1028	9900	CW26390VAA		

\* Rated GVM and axle capacities are subject to Federal, State and Territory legal requirements.

1. Mass is an estimation based only on standard model, includes fluids (no diesel fuel or Adblue®). Excludes spare tyre carrier, spare wheel, driver & tools.

2. Based on vehicle with standard wheels and tyres

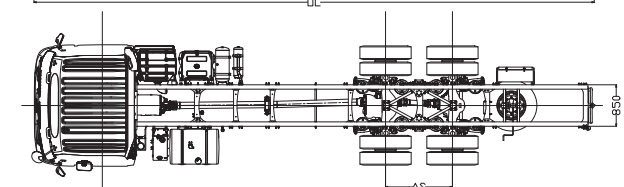
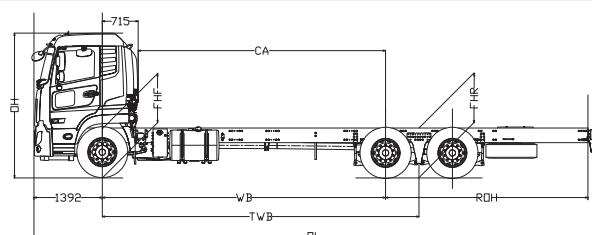
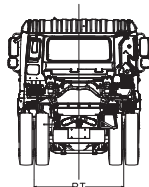

## Specifications

# GK 17 420

4x2 Tractor



## SPECIFICATIONS

<b>Power:</b>	309 kW (420 PS) @1600 rpm
<b>Torque:</b>	1900 Nm (1401 lb.ft) @ 950 rpm
<b>Transmission:</b>	ESCOT-VI automated manual transmission (AMT)
<b>Suspension:</b>	Air bag suspension
<b>Overall length:</b>	6262 mm
<b>Overall width:</b>	2490 mm
<b>Wheelbase:</b>	3850 mm (E-wheelbase)
<b>GVM:</b>	16500 kg
<b>GCM:</b>	45000 kg

Note: GK 17 420 shown may not be representative of actual vehicle.

## NEW QUON UNIQUE FEATURES



### SMART FUEL EFFICIENCY AND RESPECT FOR THE ENVIRONMENT

GH11 engine: even more fuel efficient, powerful and clean.



### SMART UPTIME

New Quon has been designed to further optimise uptime, with superior reliability and increased maintenance intervals.



### SMART SAFETY

Active safety has been improved with mechanical and electronic upgrades throughout.



### SMART PRODUCTIVITY

Increased payload, reduced vehicle weight.



### SMART DRIVABILITY

The cabin has been completely redesigned with the user's comfort in mind, with improved ergonomics and visibility allowing the driver to concentrate on driving.



## MECHANICAL SPECIFICATION

### ENGINE MODEL

<b>Model:</b>	GH11TC
<b>Layout:</b>	6 in-line
<b>Maximum power (rpm):</b>	309 kW (420 PS) @ 1600 rpm
<b>Maximum torque (rpm):</b>	1900 Nm (1401 lb.ft) @ 950 rpm
<b>Bore X stroke:</b>	123 mm x 152 mm
<b>Displacement:</b>	10837 cc (11 litres)
<b>Emission standard:</b>	pPNLT (Exceeds Euro 6 emission requirements)

### TRANSMISSION

<b>Make:</b>	UD Trucks		
<b>Model:</b>	ESCOT-VI		
<b>Description:</b>	Automated manual transmission (AMT) 12 forward & 2 reverse gears		
<b>Shift type:</b>	Electronic shifter with fully automatic or manual control		
<b>Gear Ratios:</b>			
<b>1<sup>st</sup></b>	14.94	<b>7<sup>th</sup></b>	3.44
<b>2<sup>nd</sup></b>	11.73	<b>8<sup>th</sup></b>	2.70
<b>3<sup>rd</sup></b>	9.04	<b>9<sup>th</sup></b>	2.08
<b>4<sup>th</sup></b>	7.09	<b>10<sup>th</sup></b>	1.63
<b>5<sup>th</sup></b>	5.54	<b>11<sup>th</sup></b>	1.27
<b>6<sup>th</sup></b>	4.35	<b>12<sup>th</sup></b>	1.00
<b>Rev 1</b>	17.48	<b>Rev 2</b>	13.73
<b>PTO capacity:</b>	500 nm @ 103% or 81%		

### BRAKES

<b>System type:</b>	Electronic Braking System (EBS) with disc brakes
<b>Front/Rear:</b>	430 mm rotors / 430 mm rotors
<b>Parking/Emergency Brake:</b>	Spring park brake
<b>Auxiliary Brake:</b>	Exhaust plus engine compression type (EEB)

### CLUTCH

<b>Type:</b>	Single plate
<b>Disc diameter:</b>	430 mm (17")

### STEERING

<b>Type:</b>	Hydraulic assist
<b>Min.turning:</b>	6200 mm

### AXLE AND LOAD

<b>Mode (rear):</b>	RSS1344C
<b>Front axle load limit:</b>	8200 kg
<b>Rear axle load limit:</b>	11500 kg
<b>Final gear ratio:</b>	3.08 or 3.36

<b>Reduction type:</b>	Single reduction
------------------------	------------------

### SUSPENSIONS

<b>Front:</b>	Front parabolic leaf spring suspension
<b>Rear:</b>	4 air bag electronically controlled

### TYRE:

<b>Tyre size front:</b>	295/80 R22.5
<b>Tyre size rear:</b>	11 R22.5
<b>Tyre brand:</b>	Bridgestone

### FUEL TANK

<b>Capacity:</b>	400 litre aluminium tank with lockable cap on LHS
------------------	---

## MAJOR DIMENSIONS

Variant	Mass (kg)				Vehicle Dimensions (mm)															UD order code
	Wheelbase code	GVM*	GCM	Total Tare <sup>1</sup>	WB	TWB	OL	OW	OH	FT	RT	AS	ROH	CA	GC <sup>2</sup>	FHF <sup>2</sup>	FHR <sup>2</sup>	Turning radius (kerb to kerb)		
UD - Air	E	16500	45000	6008	3850	3850	6262	2490	2970	2062	1851	N/A	930	2995	249	987	1010	6200	GK17420EAA	

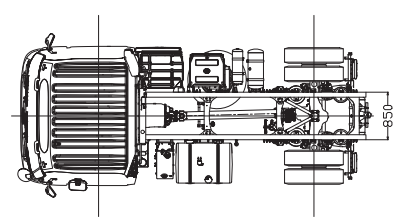
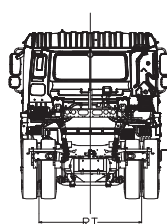
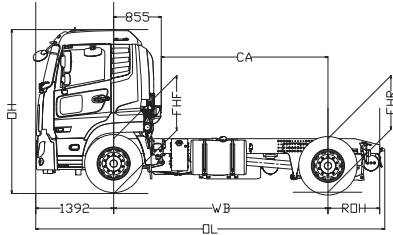
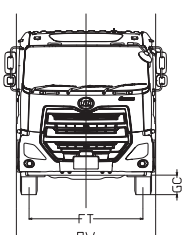

\* Rated GVM and axle capacities are subject to Federal, State and Territory legal requirements. 1. Mass is an estimation based only on standard model, includes fluids (no diesel fuel or Adblue®). Excludes spare tyre carrier, spare wheel, driver & tools. 2. Based on vehicle with standard wheels and tyres.

## Specifications

# GW 26 420

6x4 Tractor / Rigid



## SPECIFICATIONS

<b>Power:</b>	309 kW (420 PS) @ 1600 rpm
<b>Torque:</b>	1900 Nm (1401 ft.lb) @ 950 rpm
<b>Transmission:</b>	ESCOT-VI automated manual transmission (AMT)
<b>Suspension:</b>	Air bag or leaf suspension
<b>Overall length:</b>	7257 mm (H-wheelbase) 7557 mm (K-wheelbase)
<b>Overall width:</b>	2490 mm
<b>Wheelbase:</b>	3300 mm* (H-wheelbase) 3600 mm* (K-wheelbase)
<b>GVM:</b>	26000 kg
<b>GCM:</b>	55000 kg

Note: GW 26 420 shown may not be representative of actual vehicle.  
\*Wheelbase measurements are from steer axle to first drive axle.

## NEW QUON UNIQUE FEATURES



### SMART FUEL EFFICIENCY AND RESPECT FOR THE ENVIRONMENT

GH11 engine: even more fuel efficient, powerful and clean.



### SMART UPTIME

New Quon has been designed to further optimise uptime, with superior reliability and increased maintenance intervals.



### SMART SAFETY

Active safety has been improved with mechanical and electronic upgrades throughout.



### SMART PRODUCTIVITY

Increased payload, reduced vehicle weight.



### SMART DRIVABILITY

The cabin has been completely redesigned with the user's comfort in mind, with improved ergonomics and visibility allowing the driver to concentrate on driving.

# MECHANICAL SPECIFICATION

## ENGINE MODEL

<b>Model:</b>	GH11TC
<b>Layout:</b>	6 in-line
<b>Maximum power (rpm):</b>	309 kW (420 PS) @ 1600 rpm
<b>Maximum torque (rpm):</b>	1900 Nm (1401 ft.lb) @ 950 rpm
<b>Bore X stroke:</b>	123 mm x 152 mm
<b>Displacement:</b>	10837 cc (11 litres)
<b>Emission standard:</b>	pPNLT (Exceeds Euro 6 emission requirements)

## TRANSMISSION

<b>Make:</b>	UD Trucks		
<b>Model:</b>	ESCOT-VI		
<b>Description:</b>	Automated manual transmission (AMT) 12 forward & 2 reverse gears		
<b>Shift type:</b>	Electronic shifter with fully automatic or manual control		
<b>Gear Ratios:</b>			
<b>1<sup>st</sup></b>	11.73	<b>7<sup>th</sup></b>	2.70
<b>2<sup>nd</sup></b>	9.21	<b>8<sup>th</sup></b>	2.12
<b>3<sup>rd</sup></b>	7.09	<b>9<sup>th</sup></b>	1.63
<b>4<sup>th</sup></b>	5.57	<b>10<sup>th</sup></b>	1.28
<b>5<sup>th</sup></b>	4.35	<b>11<sup>th</sup></b>	1.00
<b>6<sup>th</sup></b>	3.41	<b>12<sup>th</sup></b>	0.78
<b>Rev 1</b>	13.73	<b>Rev 2</b>	10.78
<b>PTO capacity:</b>	500 nm @ 103% or 81%		

## BRAKES

<b>System type:</b>	Electronic Braking System (EBS) with disc brakes
<b>Front/Rear:</b>	430 mm rotors / 430 mm rotors
<b>Parking/Emergency Brake:</b>	Spring park brake
<b>Auxiliary Brake:</b>	Exhaust plus engine compression type (EEB)

## CLUTCH

<b>Type:</b>	Single plate
<b>Disc diameter:</b>	430 mm (17")

## STEERING

<b>Type:</b>	Hydraulic assist
<b>Min.turning:</b>	6400 mm (H-wheelbase) 6800 mm (K-wheelbase)

## AXLE AND LOAD

<b>Model (rear):</b>	RTS2370A
<b>Front axle load limit:</b>	8200 kg
<b>Rear axle load limit:</b>	21000 kg (air bag suspension) 18000 kg (leaf spring suspension)
<b>Final gear ratio:</b>	4.13 or 4.50
<b>Reduction type:</b>	Single reduction

## SUSPENSIONS

<b>Front:</b>	Parabolic leaf spring suspension
<b>Rear:</b>	8 air bag electronically controlled or Parabolic leaf spring suspension with rubber cushion

## TYRE:

<b>Tyre size front:</b>	295/80 R22.5
<b>Tyre size rear:</b>	11 R22.5
<b>Tyre brand:</b>	Bridgestone

## FUEL TANK

<b>Capacity:</b>	400 litre aluminium tank with lockable cap on LHS
------------------	---

# MAJOR DIMENSIONS

Variant	Mass (kg)				Vehicle Dimensions (mm)															
	Wheelbase code	GVM*	GCM	Total Tare <sup>1</sup>	WB	TWB	OL	OW	OH	FT	RT	AS	ROH	CA	GC <sup>2</sup>	FHF <sup>2</sup>	FHR <sup>2</sup>	Turning radius (kerb to kerb)	UD order code	
UD - Leaf	H	26000	55000	7622	3300	3985	7257	2490	2970	2062	1851	1370	2495	2445	249	1027	1091	6400	GW26420HAL	
	K			7649	3600	4285	7557							2745		1027	1091	6800	GW26420KAL	
UD - Air	H	26000	55000	7631	3300	3985	7257	2490	2970	2062	1851	1370	2495	2445	249	1027	1038	6400	GW26420HAA	
	K			7643	3600	4285	7557							2745		1030	1038	6800	GW26420KAA	

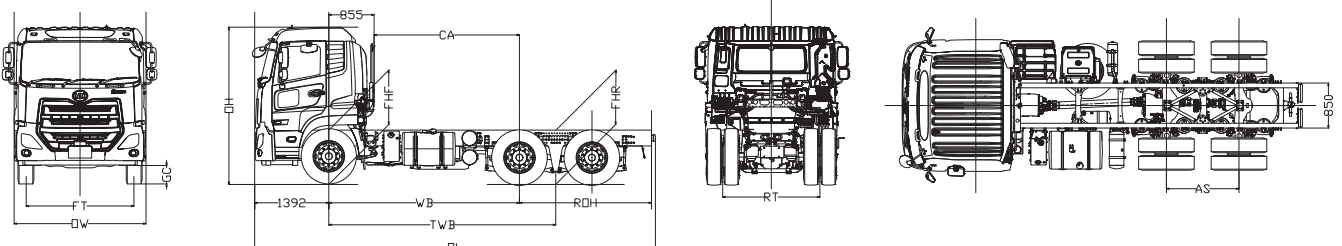

\* Rated GVM and axle capacities are subject to Federal, State and Territory legal requirements. 1. Mass is an estimation based only on standard model, includes fluids (no diesel fuel or Adblue®). Excludes spare tyre carrier, spare wheel, driver & tools.  
2. Based on vehicle with standard wheels and tyres.

## Specifications

# GW 26 460

6x4 Tractor / Rigid



## SPECIFICATIONS

<b>Power:</b>	338 kW (460 PS) @ 1800 rpm
<b>Torque:</b>	2200 Nm (1623 lb.ft) @ 1200 rpm
<b>Transmission:</b>	ESCOT-VI automated manual transmission (AMT)
<b>Suspension:</b>	Air bag or leaf suspension
<b>Overall length:</b>	7257 mm (H-wheelbase) 7557 mm (K-wheelbase)
<b>Overall width:</b>	2490 mm
<b>Wheelbase:</b>	3300 mm* (H-wheelbase) 3600 mm* (K-wheelbase)
<b>GVM:</b>	26000 kg
<b>GCM:</b>	60000 kg

Note: GW 26 460 shown may not be representative of actual vehicle.  
\*Wheelbase measurements are from steer axle to first drive axle.

## NEW QUON UNIQUE FEATURES



### SMART FUEL EFFICIENCY AND RESPECT FOR THE ENVIRONMENT

GH11 engine: even more fuel efficient, powerful and clean.



### SMART UPTIME

New Quon has been designed to further optimise uptime, with superior reliability and increased maintenance intervals.



### SMART SAFETY

Active safety has been improved with mechanical and electronic upgrades throughout.



### SMART PRODUCTIVITY

Increased payload, reduced vehicle weight.



### SMART DRIVABILITY

The cabin has been completely redesigned with the user's comfort in mind, with improved ergonomics and visibility allowing the driver to concentrate on driving.

## MECHANICAL SPECIFICATION

### ENGINE MODEL

<b>Model:</b>	GH11TD
<b>Layout:</b>	6 in-line
<b>Maximum power (rpm):</b>	338 kW (460 PS) @ 1800 rpm
<b>Maximum torque (rpm):</b>	2200 Nm (1623 ft.lb) @ 1200 rpm
<b>Bore X stroke:</b>	123 mm x 152 mm
<b>Displacement:</b>	10837 cc (11 litres)
<b>Emission standard:</b>	pPNLT (Exceeds Euro 6 emission requirements)

### TRANSMISSION

<b>Make:</b>	UD Trucks		
<b>Model:</b>	ESCOT-VI		
<b>Description:</b>	Automated manual transmission (AMT) 12 forward & 2 reverse gears		
<b>Shift type:</b>	Electronic shifter with fully automatic or manual control		
<b>Gear Ratios:</b>			
<b>1<sup>st</sup></b>	11.73	<b>7<sup>th</sup></b>	2.70
<b>2<sup>nd</sup></b>	9.21	<b>8<sup>th</sup></b>	2.12
<b>3<sup>rd</sup></b>	7.09	<b>9<sup>th</sup></b>	1.63
<b>4<sup>th</sup></b>	5.57	<b>10<sup>th</sup></b>	1.28
<b>5<sup>th</sup></b>	4.35	<b>11<sup>th</sup></b>	1.00
<b>6<sup>th</sup></b>	3.41	<b>12<sup>th</sup></b>	0.78
<b>Rev 1</b>	13.73	<b>Rev 2</b>	10.78
<b>PTO capacity:</b>	500 nm @ 103% or 81%		

### BRAKES

<b>System type:</b>	Electronic Braking System (EBS) with disc brakes
<b>Front/Rear:</b>	430 mm rotors / 430 mm rotors
<b>Parking/Emergency Brake:</b>	Spring park brake
<b>Auxiliary Brake:</b>	Exhaust plus engine compression type (EEB)

### CLUTCH

<b>Type:</b>	Single plate
<b>Disc diameter:</b>	430 mm (17")

### STEERING

<b>Type:</b>	Hydraulic assist
<b>Min.turning:</b>	6400 mm (H-wheelbase) 6800 mm (K-wheelbase)

### AXLE AND LOAD

<b>Mode (rear):</b>	RTS2370A
<b>Front axle load limit:</b>	8200 kg
<b>Rear axle load limit:</b>	21000 kg (air bag suspension) 18000 kg (leaf spring suspension)
<b>Final gear ratio:</b>	4.13 or 4.50
<b>Reduction type:</b>	Single reduction

### SUSPENSIONS

<b>Front:</b>	Parabolic leaf spring suspension
<b>Rear:</b>	8 air bag electronically controlled or Parabolic leaf spring suspension with rubber cushion

### TYRE:

<b>Tyre size front:</b>	295/80 R22.5
<b>Tyre size rear:</b>	11 R22.5
<b>Tyre brand:</b>	Bridgestone

### FUEL TANK

<b>Capacity:</b>	400 litre aluminium tank with lockable cap on LHS
<b>Optional:</b>	200 Litre auxiliary tank on RHS

## MAJOR DIMENSIONS

Variant	Mass (kg)					Vehicle Dimensions (mm)															UD order code
	Wheelbase code	GVM*	GCM	Total Tare <sup>1</sup>	WB	TWB	OL	OW	OH	FT	RT	AS	ROH	CA	GC <sup>2</sup>	FHF <sup>2</sup>	FHR <sup>2</sup>	Turning radius (kerb to kerb)			
UD - Leaf	H	26000	60000	7622	3300	3985	7257	2490	2970	2062	1851	1370	2495	2445	249	1027	1091	6400	GW26460HAL		
	K			7649	3600	4285	7557											6800	GW26460KAL		
UD - Air	H	26000	60000	7446	3300	3985	7257	2490	2970	2062	1851	1370	2495	2445	249	1027	1038	6400	GW26460HAA		
	K			7643	3600	4285	7557											6800	GW26460KAA		

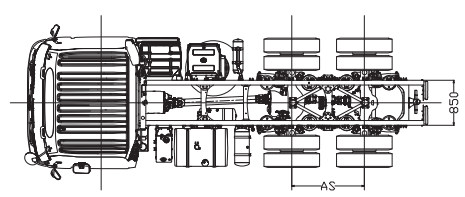
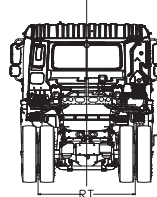
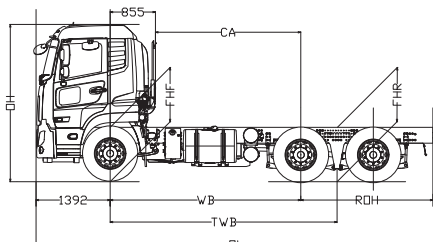
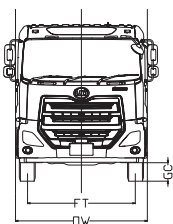

\* Rated GVM and axle capacities are subject to Federal, State and Territory legal requirements. 1. Mass is an estimation based only on standard model, includes fluids (no diesel fuel or Adblue®). Excludes spare tyre carrier, spare wheel, driver & tools.  
2. Based on vehicle with standard wheels and tyres.







**UD TRUCKS**

The specifications in this catalogue are subject to change without notification. The images shown in this catalogue are computer graphics that were prepared specifically for this catalogue. The specifications, colors, and other details of the actual vehicles might vary slightly. The addition of optional features could change the weight of the final product. For more information, please contact your nearest UD Trucks dealer. This catalogue is current as of November 2017.

---

**UD Trucks Australia**  
[udtrucks.com.au](http://udtrucks.com.au)