

# CW SERIES EURO 5

**MODEL:** **CW26-380L**  
6 x 4

GVW 26,000kg  
GCW 50,000kg



ENGINE:	
<b>Model</b>	GH11
<b>Type</b>	Six cylinder in line, 24 valve, OHC, 4 stroke direct injection, turbo charged diesel with intercooler
<b>Displacement</b>	10837cc
<b>Bore and stroke</b>	123 x 152mm
<b>Maximum output ECE</b>	378 PS (278 kW) at 1800rpm (nett)
<b>Maximum torque ECE</b>	1790 Nm (1320lb/ft) at 950rpm (nett)
<b>Maximum output JIS</b>	393 PS (289 kW) at 1800rpm (gross)
<b>Maximum torque JIS</b>	1859 Nm (1375lb/ft) at 950rpm (gross)
<b>On load max rpm</b>	2300
<b>Total Oil capacity</b>	33 litres
<b>Lubrication system</b>	Gear pump, flat tube oil cooler, 2 x full flow and 1 x by-pass oil filters.
<b>Air cleaner</b>	Primary and secondary paper element air filters.
<b>Standard air intake</b>	High mounted left hand side
<b>Emission standard</b>	ADR80/03- Euro 5
<b>Primary</b>	Selective Catalytic Reduction (SCR)
<b>AdBlue tank</b>	60 litre polymer tank with lockable cap

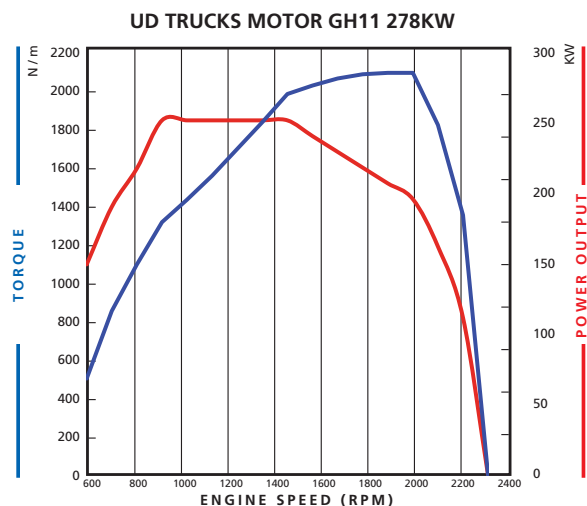

Engine Cooling System	
Radiator	Corrugated fin type
Water pump	Centrifugal
Header tank	Expansion type fitted
Temperature control	Wax pellet type thermostat
Fan	680mm mounted on viscous hub

DRIVELINE, ELECTRICAL & FUEL:	
<b>Clutch</b>	
Make	UD Trucks
Type	Dry single plate with push type diaphragm Hydraulically operated with air assist
Clutch diameter	430mm
<b>Front Axle</b>	
Model	UD Trucks Dropped Forged reverse Elliot "I" Beam Factory Rated at 8,200kg
<b>Rear Axle</b>	
Model	UD Trucks
Type	Fully floating pressed steel banjo housing
Factory rated at	10,000kg each
<b>Differential</b>	
Model	UD Trucks
Type	Single reduction hypoid
Standard Ratio	4.111:1

<b>Gearbox</b>																																	
Model	UD Trucks ATO2612D – 2 pedal operation																																
Gearshift	Fully automated manual (Escot 5) 12 forward and two reverse gears. Synchronised range and splitter gears.																																
Shift type	Electronic sequential shifter																																
Ratios	<table border="1"> <tbody> <tr><td>1st</td><td>11.73</td><td>7th</td><td>2.70</td></tr> <tr><td>2nd</td><td>9.21</td><td>8th</td><td>2.12</td></tr> <tr><td>3rd</td><td>7.09</td><td>9th</td><td>1.63</td></tr> <tr><td>4th</td><td>5.57</td><td>10th</td><td>1.28</td></tr> <tr><td>5th</td><td>4.35</td><td>11th</td><td>1.00</td></tr> <tr><td>6th</td><td>3.41</td><td>12th</td><td>0.79</td></tr> <tr><td>Reverse 1</td><td>13.73</td><td></td><td></td></tr> <tr><td>Reverse 2</td><td>10.78</td><td></td><td></td></tr> </tbody> </table>	1st	11.73	7th	2.70	2nd	9.21	8th	2.12	3rd	7.09	9th	1.63	4th	5.57	10th	1.28	5th	4.35	11th	1.00	6th	3.41	12th	0.79	Reverse 1	13.73			Reverse 2	10.78		
1st	11.73	7th	2.70																														
2nd	9.21	8th	2.12																														
3rd	7.09	9th	1.63																														
4th	5.57	10th	1.28																														
5th	4.35	11th	1.00																														
6th	3.41	12th	0.79																														
Reverse 1	13.73																																
Reverse 2	10.78																																
<b>Electrical System</b>																																	
System	24 volt negative earth																																
Batteries	2 x 12 volt 140 Ah.																																
Alternator	130 amp																																
<b>Fuel system</b>																																	
Tank Capacity	400 litre alloy tank mounted on RHS chassis																																
Fuel system	Ultra high pressure unit injectors																																
Fuel filter	Primary and secondary engine mounted filters																																

CHASSIS	Chassis		Suspension	
	Type	Ladder channel section side rails	Front	Semi-elliptic 4 taper leaf springs. 90 x 1550mm
Dimension	300 x 90 x 8mm	Spring constant	43.8 kg / mm per spring	
Material	Pressed carbon steel 55kg / mm <sup>2</sup> tensile steel	Rear	Trunion mounted leaf springs with 6 torque rods	
Brakes	<b>Brakes</b>	Spring constant	272 kg/mm	
Service	Dual line full air, wedge type, ABS, EBS with ASR. Oil mist separator and air dryer	<b>Steering &amp; Wheels</b>		
Drum dimensions		Type	Integral power assisted recirculating ball steering box	
Front	410 x 180 mm	Reduction ratio	24.1~26.8	
Rear	410 x 220 mm	Steering wheel	460mm diameter moulded polyurethane grip	
Total lining	10,280 cm <sup>2</sup>	Steering column	Fore / aft tilt, telescopic and lockable	
Parking brakes	Spring brakes acting on rear wheels	Road Wheels	Pressed steel disc 8.25 x 22.5, ISO 335mm PCD, 10 stud, 165mm offset	
Auxiliary brakes	Exhaust plus engine decompression brake	Tyres	Front: 275/70 22.5 tubeless radials Rear : 275/70 tubeless radials	

CAB & INSTRUMENTS	Gauges		Interior	
	Instrument gauges	Fuel, dual air pressure, tachometer, AdBlue gauge. Speedometer with odometer and trip meter.	Drivers seat	Cloth trimmed high-back multi adjustable air suspended seat with automatic height control. 3 point ELR lap sash seatbelts
Multi Display	Water temperature, Engine oil temperature, Engine oil pressure day, date and time, service intervals.	Passengers seat	Cloth trimmed reclining high-back type fixed seat with lift up base. 3 point ELR lap sash seatbelts	
<b>Warning Devices</b>		Sun visors	Driver and passenger side	
Warning lamps	Engine control warning, low air pressure, parking brake/ spring brake, hazard, air filter element, low oil pressure, oil filter clog, battery charge, SCR trouble, AdBlue quality	Overhead tray	Document holders on drivers and passenger side	
Indicator lamps	Turn signal, EE/exhaust brake, air heater, high beam, cruise control, non ABS trailer	Cup holder	Hot/cold holder in centre consol	
<b>Audible warning</b>		Floor covering	Vinyl	
Devices include	Low air pressure, Engine system, Engine oil low level, Engine oil pressure, Overheat, Coolant level, Engine oil temp, EBS, Large clutch load, Defective range shift warning, Reverse buzzer, N setting buzzer, AdBlue low level.	Bunk	Bed in rear of cab, cloth trimmed type	
<b>Exterior</b>		<b>Standard equipment</b>		
Type	Steel construction fully suspended forward control Meets ECE-R29 safety standard. FUPS bars standard	Control switches	Two stalk controls which incorporate Reversing lamp, roof marker lamps 1. Turn signal, lighting 2. Wiper/washer/engine/exhaust brake, hazard warning, cruise control	
Cab suspension	Full air suspension with hydraulic shock absorbers	Features	<ul style="list-style-type: none"> <li>• Door intrusion bars</li> <li>• Air conditioner/Heater demister</li> <li>• 4 mode operation with 4 speed fan</li> <li>• Engine idling control button</li> <li>• Electric windows</li> <li>• Central Locking</li> <li>• UD Trucks Multi Media double din audio system</li> <li>• Cigar lighter</li> <li>• Electric horn</li> <li>• Foot rest</li> <li>• Spare tyre</li> <li>• Equipped tyre carrier</li> <li>• Tool kit</li> </ul>	
Tilting	Electric-Hydraulic tilt system to 65 deg	Lamps	<ul style="list-style-type: none"> <li>• Halogen head lamps</li> <li>• Hazard / Turn signal / Clearance lamps</li> <li>• Stop / Tail lamps</li> <li>• Reversing Lamp</li> <li>• Roof marker lamps</li> <li>• License plate lamp</li> </ul>	
Windshield	Laminated tinted safety glass			
Windshield wiper	Three arms, dual speed with intermittent operation			
Side and rear windows	Tinted safety glass			
Cab front lid	Hinged for easy checking of maintenance (clutch fluid, coolant, engine oil)			
Mirrors	Heated and electrically operated main mirrors. Passenger side rear and downward spotter mirrors			

Dimensions & Performance

**Cab & Chassis Weights Kg**

Model CW26-380L	Front	Rear	Total
* With 20 litres of fuel, no spare wheel or tools	4390	3830	8220
* With 400 litres of fuel, spare wheel and tools	4510	4110	8620

**IMPORTANT NOTICE:** Weights obtained by weighing a vehicle on a NZ Govt. certified weighbridge. Please note that weights may vary from unit to unit.

Overall height 2920mm  
Chassis width 840mm  
Chassis height at R/A 1055mm



**UD TRUCKS**