



TECHNICAL BULLETIN TL - 25

DATE: APRIL 4, 2002
MODEL YEAR: 1986 ~ 2002
ENGINE MODEL: FE6/FE6T/FE6TZ/FE6TA 12-VALVE/FE6TA 24-VALVE
BULLETIN #: TL - 25
FILE IN THE TOOL SECTION OF THE TECHNICAL BULLETIN BINDER

FE6 CYLINDER HEAD PRESSURE TEST KIT

TOOL NOTICE

A two-piece cylinder head testing kit for pressure testing all former and new versions of the FE6 engine has been developed by SPX Corporation. The pressure test kit includes all necessary hardware for attaching the pressure plates to the cylinder head.

The new Cylinder Head Pressure Test Kit, J-45825, has been designated as necessary and essential for all UD dealers. It is projected that the new tool will be shipped directly to UD dealers by SPX Corporation during the month of June. The billing for this tool will follow directly from SPX Corporation.

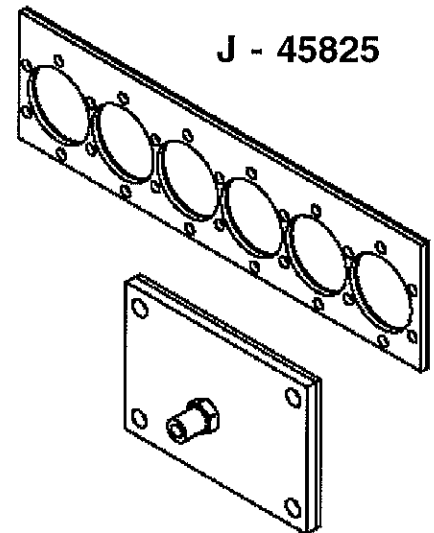

SERVICE NOTICE

The Cylinder Head Pressure Test Kit is used to pressurize the water jacket in the FE6 cylinder head to test injector sleeves and core plugs for leakage. Once the cylinder head is pressurized, it can be submerged in water or a simple squirt bottle with soapy solution can be used to verify the proper seal of injector sleeves and core plugs.

Pressure testing the cylinder head should be performed on all cylinder heads before the cylinder head is re-installed on the engine.

PROCEDURE

1. Attach the long pressure test plate on the bottom side of the cylinder head using the 26 bolts and 26 nuts provided in the Pressure Test Kit.
2. Attach the smaller pressure test plate to the forward side of the cylinder head at the thermostat housing opening using the four bolts provided in the Pressure Test Kit. Attach a suitable air chuck fitting to the smaller plate fitting.
3. Using a suitable air pressure regulator, apply 15 PSI to the cylinder head. Leaking injector sleeves or core plugs will typically show up at much lesser applied pressure. More than 15 PSI should never be applied. Normal safety precautions should be observed during this testing.